

Potting Table

(PT35U unassembled kit)

Tools Required #2 Philips or Robertson screw-driver. (wood glue optional)



Hardware:

(36)- 1-3/4 inch zinc screws
(36)- 2-1/2 inch zinc screws
(8)- 4 inch zinc screws

(8) wood dowels



- (a) 2 front legs
- (b) 2 back legs
- (c) 4 leg supports
- (d) 8 table tops
- (e) 4 aprons
- (f) 4 cleats

- (g) 1 hutch shelf
- (h) 1 hutch cap

Side Assembly

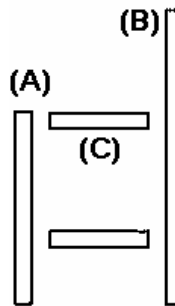
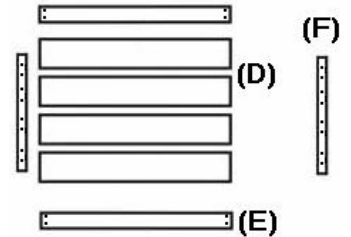
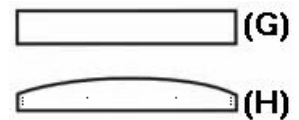

Table Assembly



Hutch Assembly



Step 1. Build Table Top

- Layout all parts as seen in the parts diagrams above.
- Set out 4 table tops finished side down.
- Place cleats on top of boards. Flush cleats with board ends and attach using 2-1/2 inch screws.
- Set aprons on edge and attach to cleats using 1-3/4 inch screws.
- Repeat for bottom table.

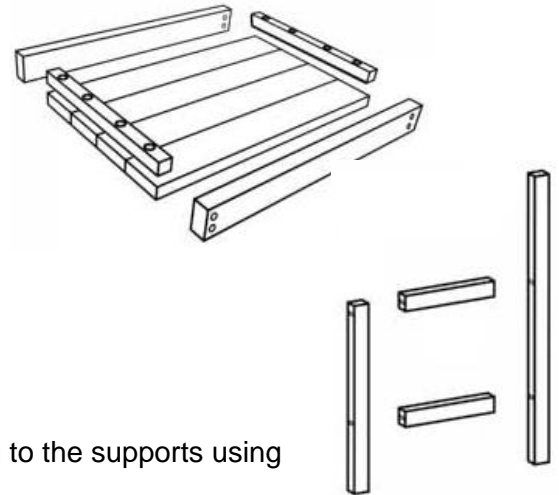

Step 2. Build Side Assembly

- Insert dowels into ends of leg supports. Attach front and back leg to the supports using 4 inch screws. Repeat for other side.

Step 3. Build Hutch

- Align hutch shelf to pre-drilled holes in hutch profile and attach using 1-3/4 inch screws.

Step 4. Final Assembly

- Insert tables between side assemblies, align table cleat with leg support and attach with 1-3/4 inch screws.
- Set hutch on top of rear legs and attach to legs using 2-1/2 inch screws.

