

ASSEMBLY INSTRUCTIONS

AND SPECIFICATIONS

MATERIAL SPECIFICATIONS
 FRAME - ϕ 1.66 x .095 ILG TUBE
 MOUNTING PLATES - 7 GA GALV
 SEATING SURFACE - .88 x 1.53 x .065 OVAL CREW TUBE

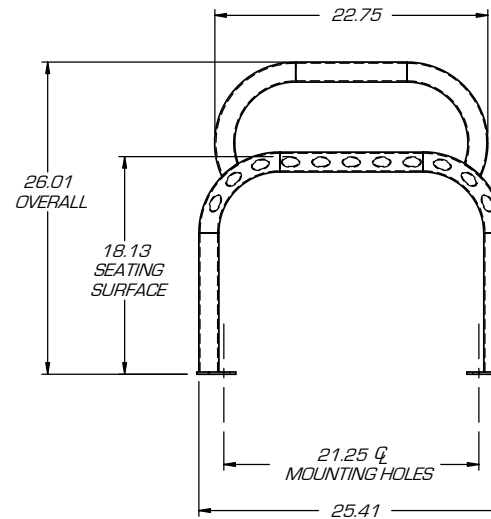
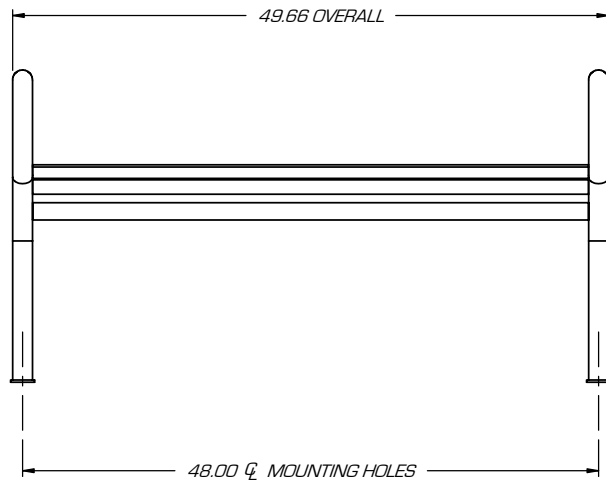
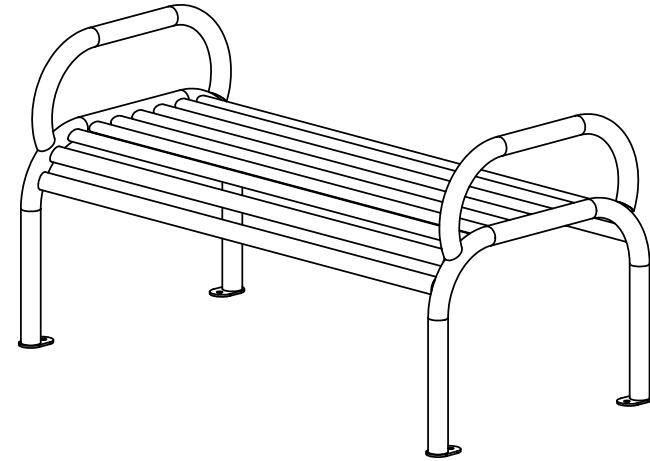

CHELSEA BACKLESS BENCH 4 FT

MODEL: 71150200

ITEM NO.	DESCRIPTION	PART NO.	QTY.
1	CHELSEA BACKLESS BENCH WELD, 4 FT	51152900	1

UNLESS OTHERWISE SPECIFIED, DIMENSIONS ARE IN INCHES

ASSEMBLY INSTRUCTIONS AND SPECIFICATIONS

MATERIAL SPECIFICATIONS
 FRAME - ϕ 1.66 x .095 ILG TUBE
 MOUNTING PLATES - 7 GA GALV
 SEATING SURFACE - .88 x 1.53 x .065 OVAL CREW TUBE

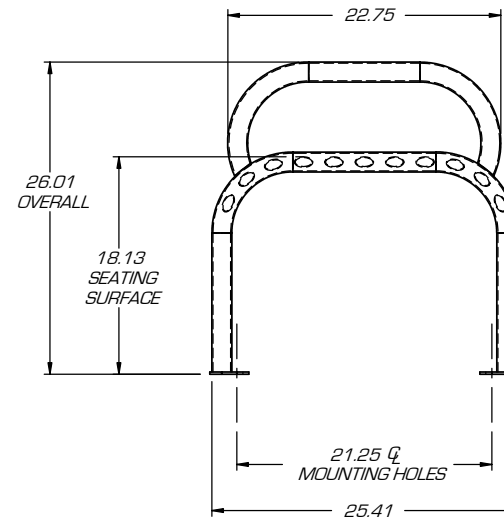
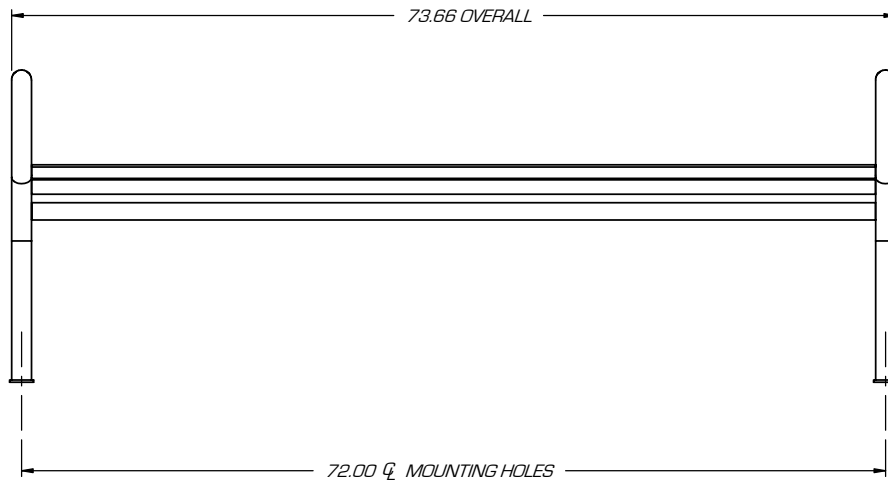
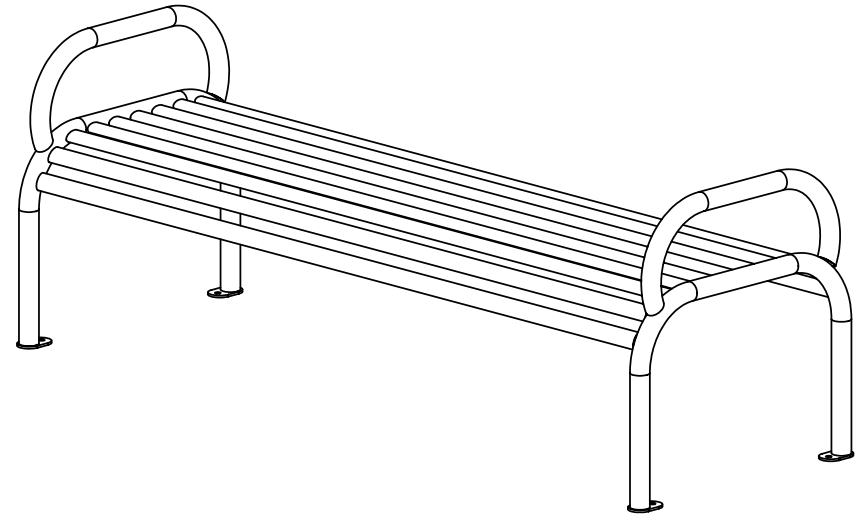

CHELSEA BACKLESS BENCH 6 FT

MODEL: 71150300

ITEM NO.	DESCRIPTION	PART NO.	QTY.
1	CHELSEA BACKLESS BENCH WELD, 6 FT	51153000	1

UNLESS OTHERWISE SPECIFIED, DIMENSIONS ARE IN INCHES

ASSEMBLY INSTRUCTIONS AND SPECIFICATIONS

MATERIAL SPECIFICATIONS
 FRAME - ϕ 1.66 x .095 ILG TUBE
 MOUNTING PLATES - 7 GA GALV
 SEATING SURFACE - .88 x 1.53 x .065 OVAL CREW TUBE

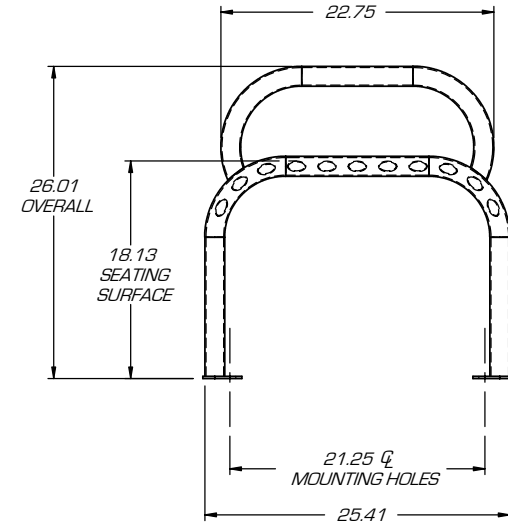
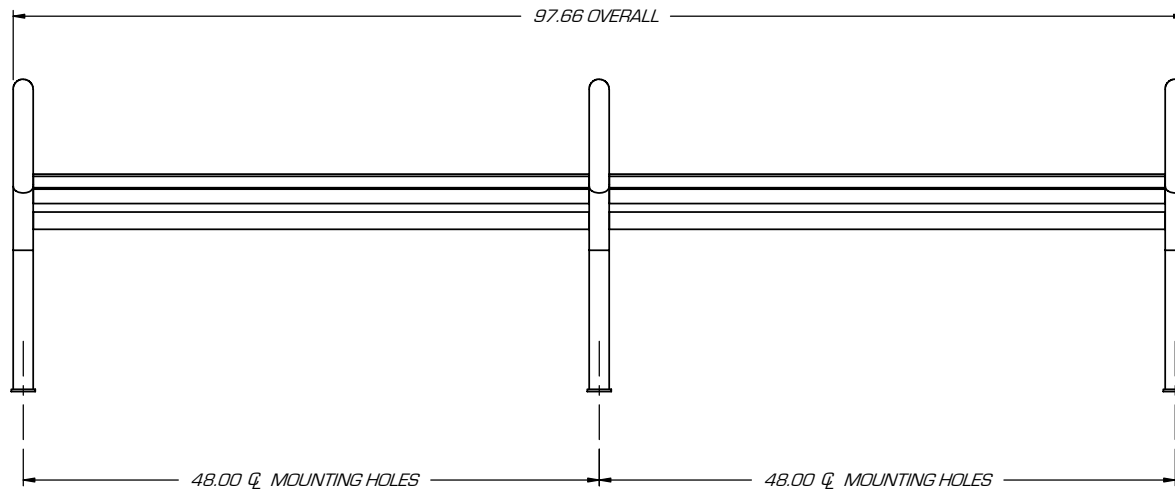
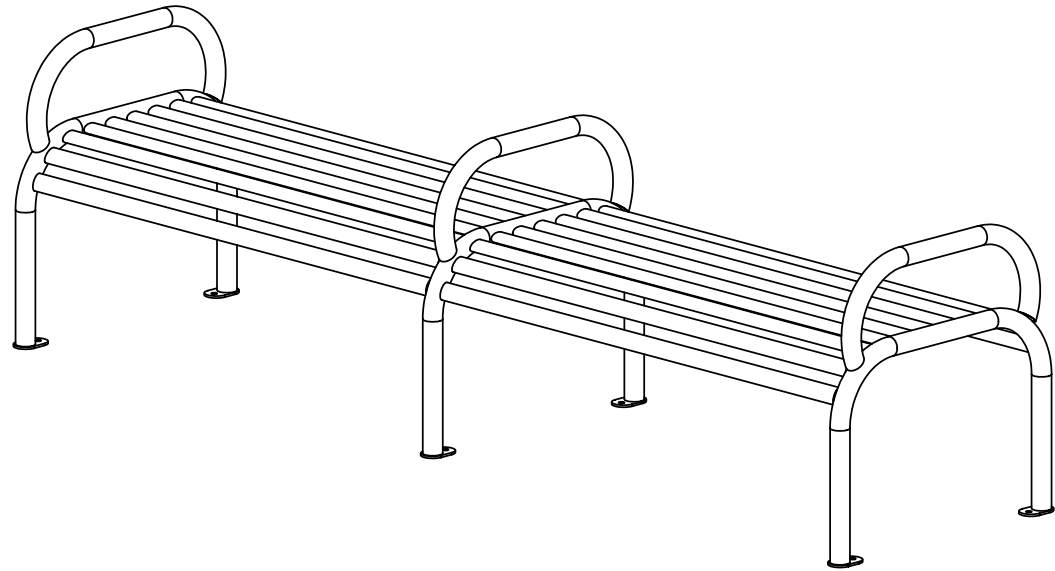

CHELSEA BACKLESS BENCH 8 FT W/ CENTRE ARM

MODEL: 71150400

ITEM NO.	DESCRIPTION	PART NO.	QTY.
1	CHELSEA BACKLESS BENCH WELD, 8 FT	51153100	1

UNLESS OTHERWISE SPECIFIED, DIMENSIONS ARE IN INCHES